

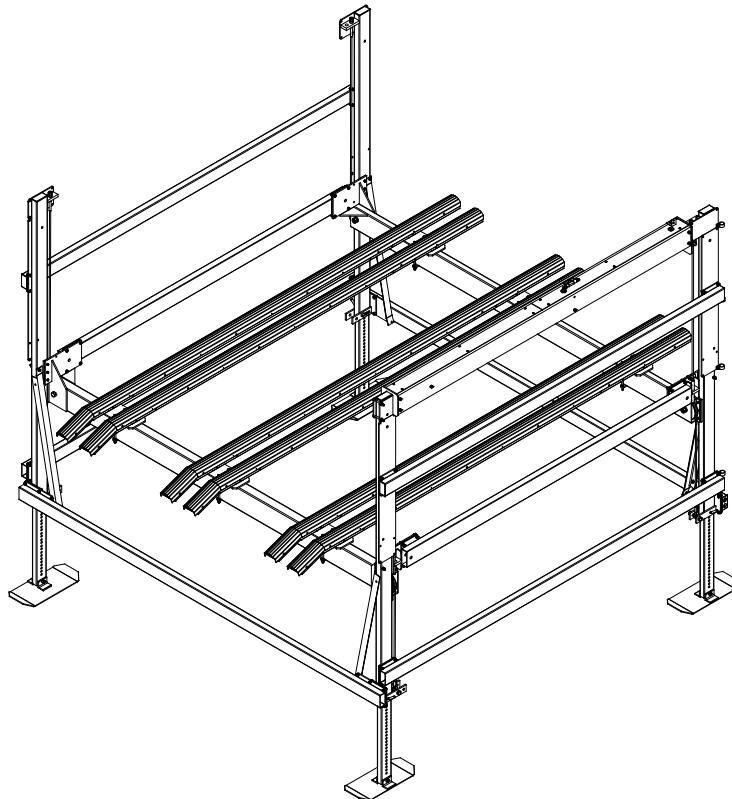

# HVL / VL ALUM / VINYL TRITON CRADLE INSTRUCTIONS

(Applies to P/Ns 3689401 & 3720106)



REIMANN & GEORGER CORPORATION  
MARINE PRODUCTS  
P/N 3689701

BUFFALO, NY  
4/23/18

## TABLE OF CONTENTS

CHAPTER	TITLE	PAGE
<b>1</b>	<b>SAFETY .....</b>	<b>1</b>
1.1	Introduction .....	1
1.2	Safety Definitions .....	1
1.3	Equipment Safety Labels .....	1
1.4	Safety Rules .....	1
<b>2</b>	<b>INSTALLATION AND SETUP .....</b>	<b>3</b>
2.1	Pre-Installation Checks .....	3
2.2	Tools Required .....	3
2.3	Cradle Positioning .....	3
2.4	Cradle Mounting Plate Assembly .....	4
2.5	Cradle Side / Bunk Assembly .....	5
2.6	Cradle / Bunk Assembly .....	6
<b>3</b>	<b>PARTS LISTS .....</b>	<b>7</b>
3.1	Alum / Vinyl Bunk Bundle .....	7
3.2	Alum / Vinyl Tritoon Cradle Carton of Parts .....	7

## LIST OF FIGURES

FIGURE	DESCRIPTION .....	PAGE
2-1.	Cradle Positioning .....	3
2-2.	Cradle Mounting Plate Assembly .....	4
2-3.	Cradle Side Assembly .....	5
2-4.	Cradle Tritoon Assembly .....	6

# 1 SAFETY

## 1.1 INTRODUCTION

Your Reimann & Georger Corporation Marine Products Tritoon Cradle Kit is designed to lift boat by pontoons rather than deck and aid in proper positioning of boat on the lift. Your Tritoon Cradle Kit is well designed and well built. However, like any other equipment, it can malfunction or become hazardous in the hands of an inexperienced and/or untrained user. Therefore, read this manual and your related Lift and equipment manuals thoroughly before installing this kit and operating your lift to provide maximum safety for all operating personnel, and to get the maximum benefit from your equipment.

## 1.2 SAFETY DEFINITIONS

A safety message alerts you to potential hazards that could hurt you or others or cause property damage. The safety messages or signal words for product safety signs are **DANGER**, **WARNING**, and **CAUTION**. Each safety message is preceded by a safety alert symbol and is defined as follows:

**DANGER:** Indicates an imminently hazardous situation which, if not avoided, **will** cause death or serious injury. This safety message is limited to the most extreme situations.

**WARNING:** Indicates a potentially hazardous situation which, if not avoided, **could** result in death or serious injury.

**CAUTION:** Indicates a potentially hazardous situation which, if not avoided, **may** result in minor or moderate injury. It may also be used to alert against unsafe practices and property-damage-only accidents.

## 1.3 EQUIPMENT SAFETY LABELS

These labels warn you of potential hazards that could cause injury. Read them carefully. If a label comes off or becomes illegible, contact a Reimann & Georger Corporation dealer for a replacement.

## 1.4 SAFETY RULES



### **WARNING:**

**DO NOT INSTALL THIS KIT AND OPERATE THE LIFT WITHOUT READING BOTH THIS MANUAL AND YOUR BOAT LIFT MANUAL. FAILURE TO DO THIS CAN LEAD TO EQUIPMENT MISUSE WITH RESULTING DAMAGE AND/OR SERIOUS PERSONAL INJURY. CONTACT YOUR RGC® MARINE DEALER IF YOU HAVE ANY QUESTIONS.**

1. Do not install this kit without first replacing any damaged or defective parts.
2. The Tritoon kit does not increase the rated capacity of the lift. Never use the lift beyond its rated capacity. This can damage the kit assembly, lift, and/or boat with resulting serious personal injury.
3. Never try using any part of this kit in an application for which it was not designed.
4. Do not weld or otherwise modify any part of this kit. Such alterations may weaken the structural integrity of the lift and void the warranty.
5. Do not try installing the tritoon brackets with the weight of the boat on the lift. This can cause equipment damage and/or personal injury.
6. The following precautions must be observed when lifting any part of this equipment:
  - a. Be sure of your footing.
  - b. Bend your knees and lift with your legs.
  - c. Hold the equipment section close to your body when lifting.
7. After the Tritoon kit is installed, the safety checks in Steps 8 through 25 must be performed on your lift prior to operation. Details on these checks are given in your lift manual.
8. Before allowing anyone to operate the lift, be sure they fully understand the proper operating procedure.

9. Do not operate the lift under the influence of drugs, alcohol, or medication.
10. Keep people and pets clear during operation of the lift.
11. Keep fingers and clothing clear of all moving parts.
12. Never allow people in the boat any time it is suspended above the water on the platform.



**WARNING:**

**DO NOT STAND OR WALK ON THE PLATFORM WHILE IT IS IN ANY RAISED POSITION. THIS CAN CAUSE SERIOUS PERSONAL INJURY.**

13. Do not allow anyone to swim or play under, near or on the lift at any time.
14. Ensure that all bolts and nuts are fastened securely on both this kit and the lift prior to operation.
15. Ensure that the frame is level and square.
16. Completely remove any user or dealer installed locking devices before operating the lift.
17. The boat must be secured on the lift before raising or lowering. Failure to do this can cause equipment damage and/or serious personal injury.
18. Check the lift periodically for frayed cables and/or binding pulleys. If any pulley binds, replace it immediately.
19. Do not try making any adjustments on the lift during operation.
20. Contact your dealer if the winch mechanism fails to perform as described in the Operation chapter of your lift manual.
21. Never tamper with the winch mechanism. This can cause equipment damage.
22. When using a direct drive or motorized friction drive, understand the use of all controls and connections provided with it.



**WARNING:**

**ALL ELECTRIC DRIVES MUST BE INSTALLED AND INSPECTED BY A CERTIFIED ELECTRICIAN IN ACCORDANCE WITH LOCAL ELECTRICAL CODES. THIS INSTALLATION MUST INCLUDE A PROPERLY WORKING GROUND FAULT CIRCUIT INTERRUPTER. (G.F.C.I.)**

23. Never use the lift to hang or store any auxiliary equipment such as boating hardware.
24. The handwheel or power drive must turn clockwise when raising the platform and counter-clockwise when lowering the platform. If the platform operates in the reverse sense, you have reeved the winch incorrectly. You **MUST** follow the winch reeving instructions in your vertical lift manual to prevent equipment damage and/or personal injury. The brake pawl must click during platform raising, indicating that the brake is operative. The self-activating brake mechanism must provide a controlled lowering of the platform.



**WARNING:**

**NEVER RELEASE THE BRAKE PAWL OF THE WINCH. THIS CAN TRIGGER AN UNCONTROLLED SPIN-DOWN OR “FREEWHEEL” OF THE HANDWHEEL. IF FREEWHEELING OCCURS, NEVER TRY TO STOP IT AS THIS CAN CAUSE SERIOUS PERSONAL INJURY.**

25. Padlock the handwheel to the post or lock out your power drive to prevent unauthorized use when your lift is left unattended.

## 2 INSTALLATION AND SET UP

### 2.1 PRE-INSTALLATION CHECKS

1. Do not assemble this kit or any other component of the lift if any part appears to be damaged.
2. Do not weld, or otherwise modify any portion of the lift. Such alterations may weaken the structural integrity of the lift and void the warranty.
3. This product has been supplied with stainless steel hardware to protect against a harsh marine environment and provide outstanding performance. Due to the chemistry and surface condition of stainless steel, there is a natural tendency for the hardware to “gall, lock up, or seize” during assembly. To prevent this from occurring, it is **highly recommended** that the anti-seize supplied in the hardware bag be applied to the mating surfaces of all stainless steel fasteners before assembly. Lubricants containing molybdenum disulfide, graphite, mica or talc may also be used.



#### **CAUTION:**

**DO NOT EXCEED THE MAXIMUM TORQUE RATING ON ALL BOLTS OF 20 FT-LBS.**



#### **WARNING:**

**FAILURE TO APPLY A SUITABLE LUBRICANT TO THE MATING SURFACES OF STAINLESS STEEL THREADED FASTENERS MAY CAUSE GALLING AND/OR SEIZING OF ASSEMBLY.**

### 2.2 TOOLS REQUIRED

1. Two, 9/16 Wrenches.

### 2.3 CRADLE POSITIONING

1. Refer to **Figure 2-1**. Position the cradle mounting plates face-up and centered on the load tubes. Measure the beam of your tritoon boat when locating the plates. Boat should remain centered on lift for best operation.

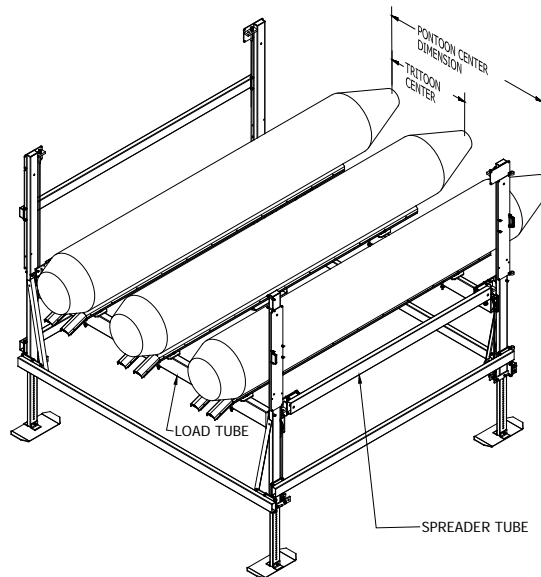

**Figure 2-1.**  
**Cradle Positioning**

## 2.4 CRADLE MOUNTING PLATE ASSEMBLY

1. **Refer to Figure 2-2.** Attach each cradle mounting plate (1) onto the load tube by aligning a 2-Hole Plate (2) underneath the tube and fastening with two 3/8 X 8-1/2 bolts (A), two 3/8 flat washers (B), two 3/8 split-lock washers (C), and two aluminum hex nuts (D). Space apart at approximate center distance between two cradle mounting plates for Pontoons or three cradle mounting plates for Tritoons.

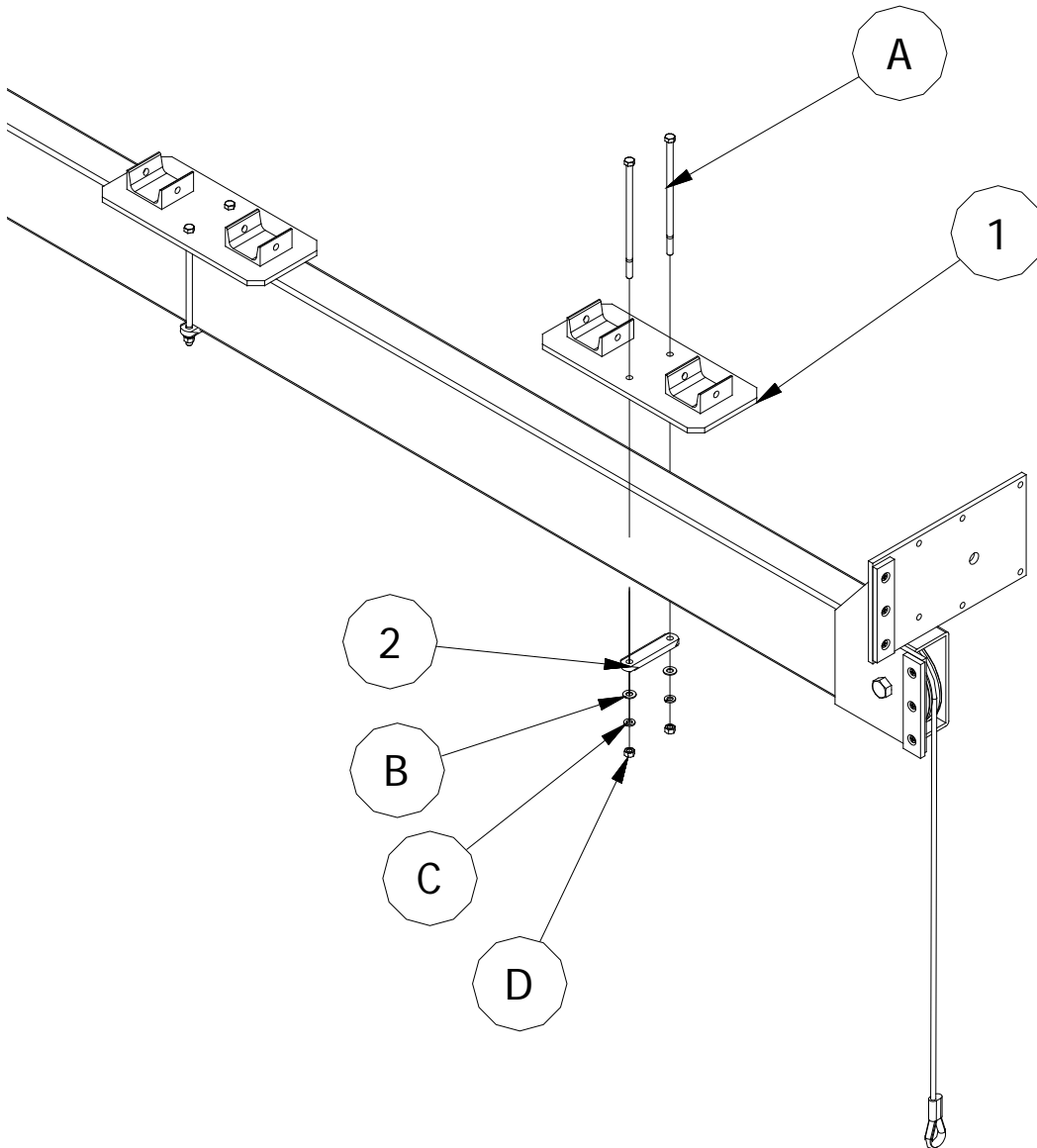

**Figure 2-2.**  
**Cradle Mounting Plate Assembly**

## 2.5 CRADLE SIDE / BUNK ASSEMBLY

1. **Refer to Figure 2-3.** Place one aluminum / vinyl bunk on top of each pair of cradle mounting plates, spanning from one load tube to the other. Align bunk pre-drilled holes with mounting channel holes (channels welded to mounting plate) and fastening with two 3/8 X 4-1/2 bolts (A), two 3/8 flat washers (B), two 3/8 split-lock washers (C), and two aluminum hex nuts (D).

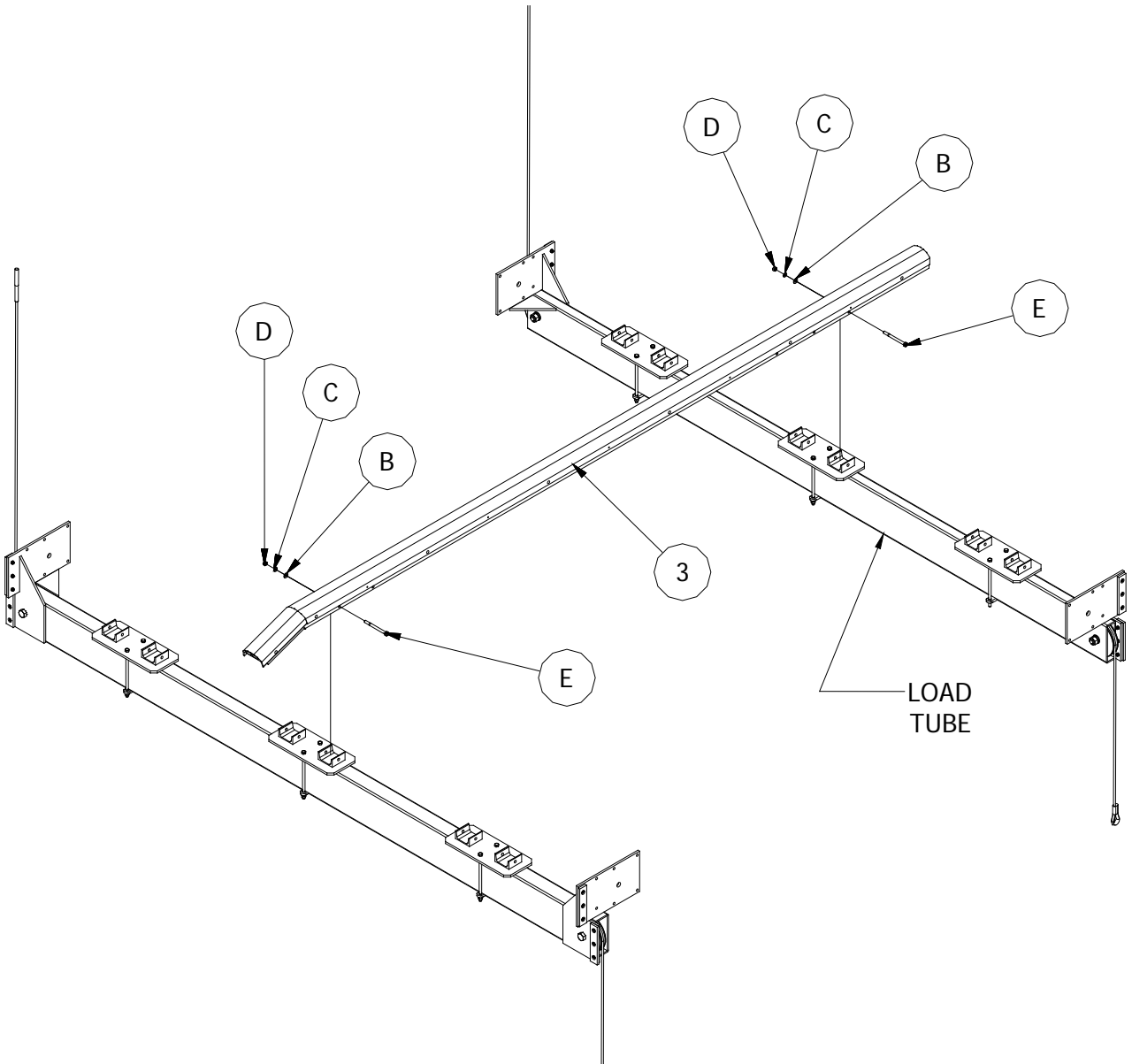
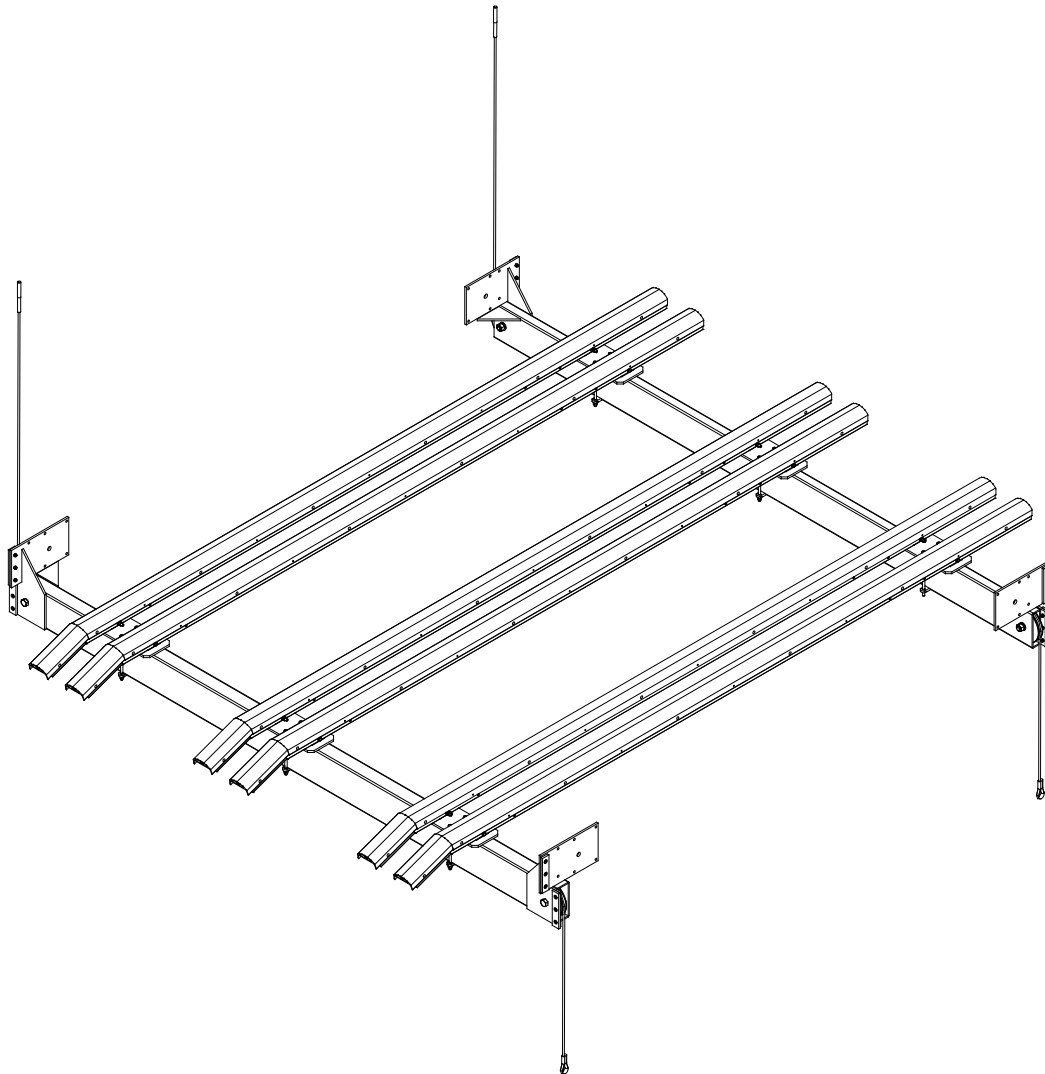

Figure 2-3.

Aluminum / Vinyl Cradle Side Assembly

**2.5 CRADLE SIDE / BUNK ASSEMBLY continued**

2. Refer to Figure 2-4. Continue to apply all required bunks: 2 outer sets for Pontoon, 3 sets for Tritoon (Shown)



**Figure 2-4.**  
**Aluminum / Vinyl Cradle Tritoon Assembly**



### 3 PARTS LISTS

Each reference number or letter in the following parts lists can be matched with the reference number or letter referred to in both the text and illustrations of Chapter 2, Installation and Setup.



**WARNING:**

**FAILURE TO APPLY A SUITABLE LUBRICANT TO THE MATING SURFACES OF STAINLESS STEEL THREADED FASTENERS MAY CAUSE GALLING AND/OR SEIZING OF ASSEMBLY.**

**3.0 3689701 VL7K-VL8K/HVL7K TRITON A/V CRADLE KIT**

**3.1 3636108 ALUMINUM / VINYL BUNK BUNDLE**

Reference	Part Number	Quantity	Description
3	3636405	6	ALUMINUM / VINYL BUNK ASSEMBLY

**3.2 3689727 ALUM / VINYL TRITON CRADLE 7K (7X2 & 7X3 LOAD TUBES) CARTON OF PARTS**

Reference	Part Number	Quantity	Description
1	3689768	6	VL/HVL P/T TOON A/V CRDL WLDMT -FLAT
	<b>3689733</b>	<b>1</b>	<b>A/V TRITON CRADLE BAG OF BOLTS 7K</b>
			<i>Consisting of:</i>
2	3606921	6	2-HOLE PLATE 3"
A	5890151	12	3/8-16 x 8-1/2 HHCS
B	5896406	24	3/8 SAE FLAT WASHER
C	5806243	24	3/8 SPLIT-LOCK WASHER
D	5840104	24	3/8 HEX NUT -ALUM
E	5896262	12	3/6-16 x 4-1/2 HHCS

## **TWO YEAR LIMITED WARRANTY**

### **Reimann & Georger Corporation Marine Products**

This product is warranted by RGC® Marine Products to the original purchaser to be free from defects in material and workmanship under normal use for a period of two years from the date of purchase.

During the warranty period, and upon proof of purchase, the product will be repaired or replaced (with the same or similar model) at our option, without charge for either parts or labor when serviced at RGC® Marine Products.

Upon completion of repair, the unit will be returned to the customer freight prepaid. The warranty will not apply to this product if it has been misused, abused, or altered.

NEITHER THIS WARRANTY OR ANY OTHER WARRANTY, EXPRESS OR IMPLIED, INCLUDING IMPLIED WARRANTIES OF MERCHANTABILITY, SHALL EXTEND BEYOND THE WARRANTY PERIOD. NO RESPONSIBILITY IS ASSUMED FOR ANY INCIDENTAL OR CONSEQUENTIAL DAMAGES. SOME STATES DO NOT ALLOW EXCLUSION OR LIMITATION OF INCIDENTAL OR CONSEQUENTIAL DAMAGES, SO THE ABOVE LIMITATIONS OR EXCLUSIONS MAY NOT APPLY TO YOU.

This warranty gives you specific legal rights, and you may also have other rights which vary from state to state.