

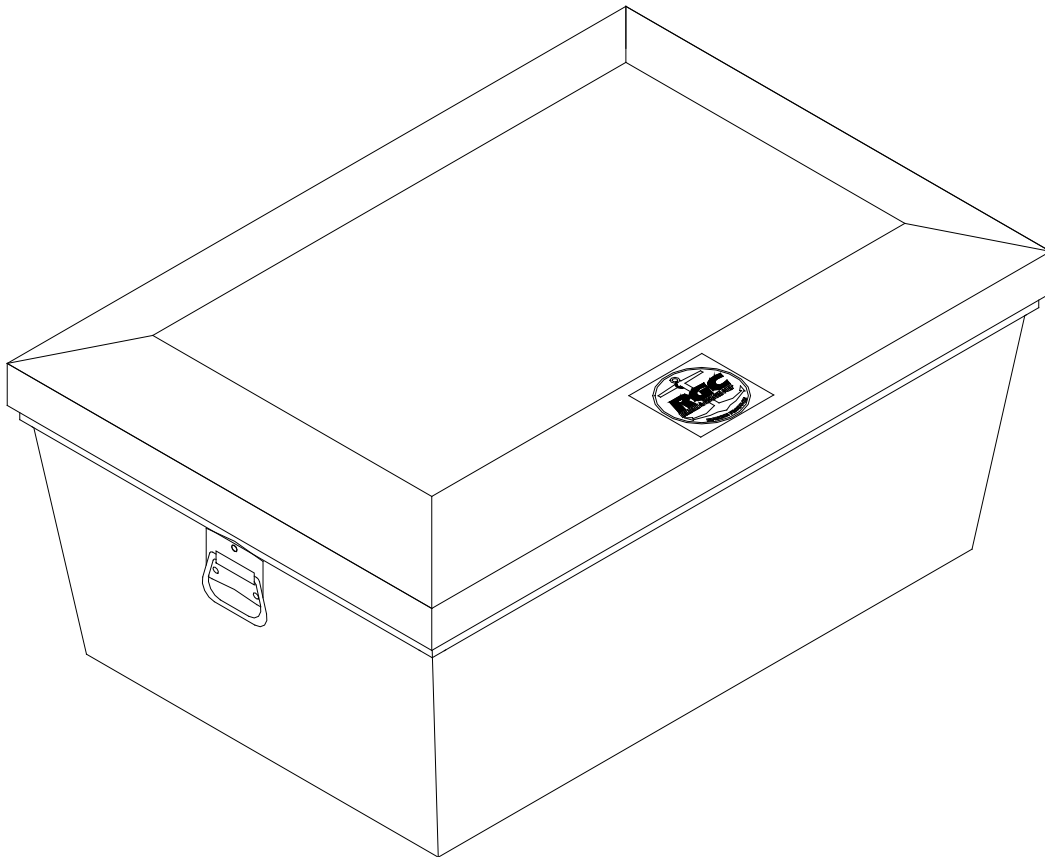

# HL-HVL HYDRAULIC POWER UNIT 12VDC

## GEM<sub>(2014)</sub>

(Applies to P/Ns 3641611 & 4136104)



REIMANN & GEORGER CORPORATION  
MARINE PRODUCTS  
P/N 6114601

BUFFALO, NY  
04/23/18

## TABLE OF CONTENTS

CHAPTER	TITLE	PAGE
<b>1</b>	<b>SAFETY .....</b>	<b>1</b>
1.1	Introduction .....	1
1.2	Safety Definitions .....	1
1.3	Equipment Safety Labels .....	1
1.4	Equipment and Personnel Safety .....	1
1.5	Installation Safety .....	2
1.6	Operating Safety .....	2
<b>2</b>	<b>SPECIFICATIONS .....</b>	<b>3</b>
2.1	Technical Data .....	3
2.2	Nameplate and Serial Number Tag .....	3
2.3	Optional Equipment .....	4
<b>3</b>	<b>INSTALLATION AND SETUP .....</b>	<b>5</b>
3.1	Pre-Installation Checks .....	5
3.2	Prior to Set Up .....	5
3.3	Making Power Connections .....	5
<b>4</b>	<b>OPERATION .....</b>	<b>7</b>
4.1	Before Operating the Lift .....	7
4.2	Testing Lift Operation .....	7
4.3	Testing Lift Operation With Remotes .....	8
4.4	Raising And Lowering The Boat .....	8
4.5	Securing Lift When Not in Use .....	8
<b>5</b>	<b>INSPECTION AND MAINTENANCE .....</b>	<b>9</b>
5.1	General Maintenance Rules .....	9
5.2	Battery Maintenance .....	9
5.3	Remote Control Information .....	10
5.4	Annual Inspection .....	10
5.5	Storage Procedure .....	11
5.6	Hydraulic System Flush .....	12
<b>6</b>	<b>TROUBLESHOOTING .....</b>	<b>13</b>
<b>7</b>	<b>PARTS LISTS .....</b>	<b>18</b>
7.1	HL Power Unit .....	18
<b>FIGURE</b>	<b>DESCRIPTION</b>	<b>PAGE</b>
2-1	Typical Product Nameplate .....	3
6-1	HL & HVL Power Unit Pressure Test .....	15
6-2	HL & HVL Power Unit Electrical Schematic .....	16
6-4	12V Solar Panel .....	17
7-1	Complete HL & HVL Power Unit Assembly .....	19

# 1 SAFETY

## 1.1 INTRODUCTION

Your Reimann & Georger Corporation Marine Products Hydraulic Lift has been engineered to provide lifting performance, long term economics and safety advantages that no other type can match. However, even a well-designed and well-built lift can malfunction or become hazardous in the hands of an inexperienced and/or untrained user. Therefore, read this manual, and related equipment manuals thoroughly before operating your lift to provide maximum safety for all operating personnel, and to get the maximum benefit from your equipment.



### **WARNING:**

**DO NOT OPERATE THIS LIFT WITHOUT STUDYING THIS ENTIRE MANUAL. FAILURE TO DO THIS CAN LEAD TO EQUIPMENT MISUSE WITH RESULTING SERIOUS PERSONAL INJURY AND/OR DAMAGE. CONTACT YOUR RGC® MARINE DEALER IF YOU HAVE ANY QUESTIONS.**

## 1.2 SAFETY DEFINITIONS

A safety message alerts you to potential hazards that could hurt you or others or cause property damage. The safety messages or signal words for product safety signs are **DANGER**, **WARNING**, and **CAUTION**. Each safety message is preceded by a safety alert symbol and is defined as follows:

**DANGER:** Indicates an imminently hazardous situation that, if not avoided, **will** cause death or serious injury. This safety message is limited to the most extreme situations.

**WARNING:** Indicates a potentially hazardous situation which, if not avoided, **could** result in death or serious injury.

**CAUTION:** Indicates a potentially hazardous situation which, if not avoided, **may** result in minor or moderate injury. It may also be used to alert against unsafe practices and property-damage-only accidents.

## 1.3 EQUIPMENT SAFETY LABELS

These labels warn you of potential hazards that could cause injury. Read them carefully. If a label comes off or becomes illegible, contact a Reimann & Georger Corporation dealer for a free replacement.

## 1.4 EQUIPMENT AND PERSONNEL SAFETY

1. Do not use the lift, control box, or the remote control if any item shows any signs of damage.
2. Do not expose the internal control box components or remote control to water or inclement weather conditions.
3. Understand the use of all controls and connections provided with the control box.
4. Never operate the lift with a substitute hydraulic power supply. Use only the control box provided with the lift.
5. Do not store any articles in the control box, as this can damage the pump or electrical system.
6. Do not allow persons other than authorized service personnel to repair any part of this equipment.
7. Do not exceed the rated maximum lifting capacity of this equipment.
8. Never try lifting anything other than a boat with this equipment.
9. Never allow people in the boat any time it is suspended above the water on the platform or when the lift is in use.
10. Do not stand or walk on the loading platform while it is in any raised position.
11. Do not allow anyone to swim or play under, near or on the lift at any time. Raise the bunks out of the water when leaving the lift unattended to allow swimmers to see its location.

12. Never use the lift to hang or store any auxiliary equipment such as boating hardware.
13. Never operate the lift during an electrical storm.

### **1.5 INSTALLATION SAFETY**

1. Do not weld or otherwise modify the lift. Such alterations may weaken the structural integrity of the lift and void the warranty.
2. All lifting accessories such as pontoon brackets, pivoting bunks, and guide-ons, must be commercially manufactured, and be properly maintained and installed.
3. Ensure that the frame is level and square.
4. The following precautions must be observed when lifting any part of this equipment:
  - a. Be sure of your footing.
  - b. Bend your knees and lift with your legs.
  - c. Hold the equipment section close to your body when lifting.

### **1.6 OPERATING SAFETY**

1. Before allowing anyone to operate the lift, be certain they fully understand the proper operating procedure.
2. Completely remove any user or dealer installed locking devices before operating the lift.
3. Follow the Pre-Lifting Checklist before operating.
4. Ensure the center of gravity of the boat is between forward load tube and rear foot plates.
5. Do not try lifting or launching your boat in rough water conditions. This can damage your boat and/or the lift.
6. The boat must be stored with the lift in the over center position.
7. A clear visual path is required when using a remote transmitter. Obstacles, radio frequency interference, and weak transmitter batteries will degrade the performance and range of your remote transmitter.
8. Keep people and pets clear during operation of the lift.
9. Keep all clothing and all body parts clear of moving parts.
10. Never adjust or service the lift during operation or while connected to the control box.
11. Do not adjust the components in the control box while operating the lift.
12. Completely lower the platform before performing any type of maintenance or repair.
13. Never allow anybody to work in or on the boat when it is suspended above the water on the lift.
14. At end of operation, secure the control box and the lift to prevent unauthorized use. Never assume you will find the equipment in the same condition in which you left it.
15. Never operate the remote control or hydraulic power unit when connecting or disconnecting hydraulic hoses.
16. Do not operate the lift when under the influence of drugs, alcohol, or medication.

## 2 SPECIFICATIONS

### 2.1 TECHNICAL DATA

Model	<b>4136104</b>	<b>3641611</b>
Power Unit used On	HL lifts	HVL lifts
Control Box Weight	61 lbs.	60 lbs.
Hydraulic Reservoir Capacity	One gallon	One gallon
Maximum UP Pressure	2300 psi	2600 psi
Maximum DOWN Pressure	2000 psi	2000 psi
Pump Flow – Full Load	1.2 GPM	1.2 GPM
Flow restrictor on power unit	Yes	No
Electrical Power	12V DC	12V DC
Gem Remote Control	Standard	Standard
AC Charger	Optional	Optional
Solar Panel	Optional	Optional

### 2.2 NAMEPLATE AND SERIAL NUMBER TAG

It is important to identify your lift completely and accurately whenever ordering spare parts or requesting assistance in service. There are two product nameplates for each lift; the nameplate on the HL lift is located at the top of the Right-Hand Forward Lift Arm, the nameplate on the HVL lift at the top of 'B' leg and another nameplate inside the control box. Each label shows the model and serial numbers and capacity rating. The lift label should appear as the sample nameplate shown in Figure 2-1. Record lift information from both nameplates below for future reference.

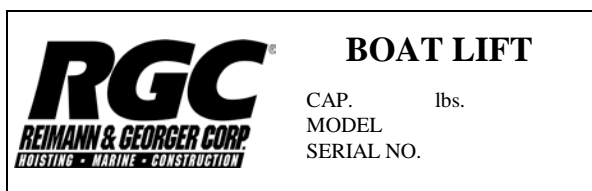

**Figure 2-1.**  
**Typical Product Nameplate**

#### HYDRAULIC LIFT NAMEPLATE INFORMATION

**MODEL** \_\_\_\_\_

**SERIAL NUMBER** \_\_\_\_\_

**CAPACITY RATING** \_\_\_\_\_

#### CONTROL BOX NAMEPLATE INFORMATION

**MODEL** \_\_\_\_\_

**SERIAL NUMBER** \_\_\_\_\_

**CAPACITY RATING** \_\_\_\_\_

### 2.3 OPTIONAL EQUIPMENT

The following options are available which enable you to customize your lift for your particular operation. Installation instructions are provided as part of each option kit.

1. **AC Charger**—Provides an additional method of recharging 12 volt DC battery. Compensating for either high usage of boat lift, or insufficient solar energy to recharge battery completely.
2. **Solar Panel**—Provides an additional method of recharging 12 volt DC battery. Compensating for either high usage of boat lift, or lack of an electric power source to recharge battery completely.
3. **Solar Panel mounting bracket kit**—Provides a mounting of the solar panel above the canopy. The solar panel bracket mounts on the vertical canopy extension leg and can be positioned to optimize afternoon sun.

## 3 INSTALLATION AND SETUP

### 3.1 PRE-INSTALLATION CHECKS

1. Do not use power unit if any part shows any sign of damage.
2. All hydraulic power unit accessories such as AC charger, solar panel, solar panel mounting bracket and power unit shelf bracket shall be commercially manufactured, and be properly maintained and installed. Consult the manufacturer's separate instructions provided for these accessories.

### 3.2 PRIOR TO SETUP

1. The lift assembly instructions refer to the placement of hydraulic power unit in terms of forward, rear, right-hand and left-hand. The rear of the lift corresponds to the rear of the boat.
3. This product has been supplied with stainless steel hardware to protect against a harsh marine environment and provide outstanding performance. Due to the chemistry and surface condition of stainless steel, there is a natural tendency for the hardware to "gall, lock up, or seize" during assembly. To prevent this from occurring, it is **highly recommended** that the anti-seize supplied in the hardware bag be applied to the mating surfaces of all stainless steel fasteners before assembly. Lubricants containing molybdenum disulfide, graphite, mica or talc may also be used.



#### **WARNING:**

**FAILURE TO APPLY A SUITABLE LUBRICANT TO THE MATING SURFACES OF STAINLESS STEEL THREADED FASTENERS MAY CAUSE GALLING AND/OR SEIZING OF ASSEMBLY.**

### 3.3 MAKING POWER CONNECTIONS

1. Before making any hydraulic connections, inspect all hydraulic lines, fittings and hoses for leaks and risks of rupture as follows:
  - a. Inspect each hydraulic line, fitting, and hose for breaks, cracks, worn spots, bulges, chemical attack, kinks or any other damage. Never try to stop any detected leak with any body parts. Do not put your face close to suspected leaks. Hold a piece of cardboard close to suspected leaks and then inspect the cardboard for signs of hydraulic oil.
  - b. Replace a damaged line, fitting or hose immediately. Never repair the part.



#### **WARNING:**

**LIQUID UNDER HIGH PRESSURE CAN PIERCE THE SKIN, CAUSING DEATH OR SERIOUS INJURY. IN CASE OF INJURY, GET IMMEDIATE MEDICAL ATTENTION.**

3. Wipe the mating surfaces of the hose couplings as well as the control box couplings with a clean rag prior to making connection.
4. Insert the hoses through the flexible cable boot in the back of the control box. Connect the hose couplings.
5. If the quick connect fittings are difficult to attach, relieve some of the pressure in the system by pushing in on the tip of the male hose connector. Pressing the tip against a clean hard surface is suggested. Use caution not to damage the fitting. This will release a small amount of fluid, which is acceptable. Once the pressure has been released, you should be able to connect both hoses.



#### **WARNING:**

**ENSURE HYDRAULIC HOSES ARE PROPERLY CONNECTED AND IN GOOD CONDITION.**

6. Ensure that the hydraulic fluid supply is adequate.

7. Attach the red battery lead to the positive battery terminal, and the black lead to the negative terminal. Tighten each wing nut with a pair of pliers, as even a slightly loose connection can cause the battery terminals to heat up. Keep battery terminals clean with a corrosion protective coating.



**WARNING:**

**FOLLOW THE SAME SAFETY RULES WHEN WORKING INSIDE THE POWER SUPPLY BOX AND AROUND THE BATTERY THAT APPLY TO ANY CAR OR BOAT BATTERY. A BATTERY CAN EXPLODE AND CAUSE PERSONAL INJURY AND/OR EQUIPMENT DAMAGE.**

8. Verify that the system is switched “on” using the on/off switch located inside the hydraulic supply box on the top of the electrical control box.
9. If the optional solar panel is supplied, the solar panel must be mounted in a suitable location. Mount the solar panel so that it faces toward the south and angled toward the afternoon sun. Route the plug end of the solar panel through the flexible cable boot in the back of the control box. Connect to the mating connector in the wiring harness.
10. If the optional AC charger is supplied, mount the charger to left side of the box. Connect the red wire to the positive battery terminal. Connect the black wire to the battery negative terminal. Run the AC power cord through the flexible cable boot in the back of the control box and plug the AC charger in.
11. If the optional light bar will be used on the lift, route the light bar wire through the flexible cable boot in the back of the control box and plug into the light connector. Using UV stabilized nylon cable ties, (black zip ties) attach the wire and the hydraulic hoses to the lift frame.



## 4 OPERATION

### 4.1 BEFORE OPERATING THE LIFT

1. Review and follow all the safety precautions given in Chapter 1.
2. Do not use the lift if it shows any signs of damage.
3. Ensure that all bolts and nuts are fastened securely prior to operation.
4. Ensure that the frame is square and that the lift sits level. (see Sec. 3.11)



**WARNING:**

**IF THE FRAME IS NOT SQUARE OR THE LIFT IS NOT LEVEL, BINDING MAY RESULT. THIS CAN CAUSE PERSONAL INJURY AND/OR EQUIPMENT DAMAGE.**

5. Never try lifting anything other than a boat with this lift.



**WARNING:**

**NEVER TRY TO USE THIS EQUIPMENT BEYOND ITS RATED CAPACITY. THIS CAN DAMAGE THE LIFT AND/OR BOAT RESULTING IN PERSONAL INJURY.**

**THE BOAT MUST BE PROPERLY POSITIONED ON THE LIFT BEFORE DOING ANY RAISING OR LOWERING. FAILURE TO DO THIS CAN CAUSE PERSONAL INJURY AND/OR EQUIPMENT DAMAGE.**



**WARNING:**

**MAKE SURE THE VENTED PLUG IS INSTALLED ON THE HYDRAULIC TANK BEFORE OPERATING THE HYDRAULIC POWER UNIT.**

6. Never try to lift or launch your boat in rough water conditions. This can damage your boat and/or the lift.
7. Follow the Pre-Lifting Checklist before operating.
8. Read and know the instructions and ensure that everyone understands the proper operating procedure.
9. Understand the use of all the controls and connections provided with the power supply and the remote transmitter.

### 4.2 TESTING LIFT OPERATION

After the lift installation is complete, it is important to test it for proper functioning before any load is applied. Proceed as follows:

1. Use the up/down switch inside the control box to cycle the lift up and down. Ensure that the hydraulic hoses are not binding or being pinched by any part of the lift.



**WARNING:**

**DO NOT STAND OR WALK ON THE LIFT PLATFORM WHILE IT IS IN ANY RAISED POSITION. THIS CAN CAUSE SERIOUS PERSONAL INJURY.**

2. The loading platform should move up and down smoothly without excessive stress or squeaking. If there is excessive squeaking or binding, check that all pivot pins are properly lubricated.
3. After cycling the lift a couple of times, inspect all hardware to ensure that they are still secure and tight. Also test the remote control and underwater lighting system. Ensure the hydraulic fluid level in pump reservoir remains up to the base of filler neck.

4. Contact your authorized dealer if the hydraulic system fails to perform as described in this section. Do NOT tamper with either system.

#### 4.3 TESTING LIFT WITH REMOTES

1. Press the 'UP' button to raise the lift platform. Press the 'DOWN' button to lower the lift platform.
2. Press both the "UP" & "DOWN" button to turn on light output (if equipped). Press the "UP" & "DOWN" buttons a second time to turn the lights off.

#### 4.4 RAISING AND LOWERING THE BOAT

1. Position the boat so that the boat's center of gravity is between forward and rear support legs.
2. Carefully raise the platform until the bunks "capture" the boat.



#### **WARNING:**

**NEVER ALLOW PEOPLE IN THE BOAT ANY TIME IT IS SUSPENDED ABOVE THE WATER ON THE LIFT.**

3. Keep fingers and clothing clear of all moving parts. Keep people clear during operation of the lift.
4. Stop the lift again and check the stability of the lift. Ensure that it is remaining level and will not topple over.
5. Continue lifting the boat, closely observing the position of the lift, until the platform is in the fully upright and over center position.
6. Remove the boat from the lift and check to see that the lift is still level. If not, the legs will have to be re-adjusted.



#### **CAUTION:**

**ALWAYS ADJUST THE HEIGHT OF THE LIFT TO LIMIT WAVE ACTION AGAINST THE HULL. WAVE ACTION CAN SERIOUSLY DAMAGE THE LIFT AND/OR YOUR BOAT.**

7. Two weeks after installation, check to see that the lift is still level, as it may have settled over time. Readjust the legs as described above and repeat this inspection and adjustment procedure at the frequency found necessary.
8. After removing the boat from the lift, re-tighten the bunk bolts as required.

#### 4.5 SECURING LIFT WHEN NOT IN USE

1. Make the lift visible by leaving the platform in any elevated position when it is not loaded with a boat. This prevents the lift from being a hidden underwater obstruction, and protects the bunks from prolonged water immersion.
2. Lock out your control box to prevent unauthorized use when your boat lift is unattended. Never assume you will find the lift in the same condition that you left it.
3. When storing the boat on the lift, the following additional precautions must be observed:
  - a. (HL lift only) When storing the boat, the platform must be in the upright over center gravity lock position for maximum safety. The over center position will prevent the boat from lowering if any hydraulic leak occurs.
  - b. Position the boat on the platform so that the boat's center-of-gravity is between the front lift arm and the rear foot plates when in the down position.
  - c. Prevent rainwater from accumulating in your boat when leaving it on the lift for long term storage. A boat that has water in it from a rainstorm could exceed the recommended weight capacity of the lift. **Just 1 gallon of water weighs over 8 pounds.** Be sure to remove the plug while the boat is up on the lift. Make sure you replace the plug prior to launching your boat.

## 5 INSPECTION AND MAINTENANCE

### 5.1 GENERAL MAINTENANCE RULES

1. Do not allow persons other than authorized service personnel to repair this equipment.
2. Completely lower the platform before performing any type of maintenance or repair.



#### **WARNING:**

**NEVER ALLOW ANYBODY TO WORK IN OR ON THE BOAT WHEN IT IS SUSPENDED ABOVE THE WATER ON THE LIFT.**



#### **WARNING:**

**BEFORE STARTING ANY MAINTENANCE ON THE LIFT, DISCONNECT AND LOCK OUT THE POWER SUPPLY TO PREVENT ACCIDENTAL OPERATION.**

3. Immediately replace any components found to be defective.



#### **CAUTION:**

**POOR OR IMPROPER MAINTENANCE CAN LEAD TO EQUIPMENT DAMAGE OR FAILURE.**

### 5.2 BATTERY MAINTENANCE

1. Use a 12-volt, group 27 marine deep-cycle battery with a minimum of 500 CCA, or with a reserve capacity of 160 amp hours or more. We recommend the following batteries: U.S. Battery Model 27 TMX, Trojan Battery Model 27 TMX or Rolls Battery Engineering Model 27112XJM. Reserve capacity is the most important feature.
2. The lift has an energy capacity of about 20 full cycles using a new battery with a reserve capacity of 160 amp hours. However, avoid dipping below 50% battery capacity because the solar panel will have trouble recovering from such a deep draw. For constant usage, we recommend usage of the optional AC charger connected to the battery on a full time basis.
3. The following table lists maximum monthly full lifting cycles (down and up), using a single solar panel, to keep the battery capacity at a steady state energy level. The capacity of the battery will allow for additional cycles for any particular month. The values assume all-day exposure with typical seasonal weather.

<b>Month</b>	<b>Cloudy northern climate</b>	<b>Sunny southern climate</b>
January	2 cycles	27 cycles
February	8	29
March	14	29
April	18	31
May	21	27
June	22	25
July	24	28
August	24	31
September	19	29
October	12	29
November	4	28
December	1	25

If the solar panel does not keep the battery charged, try any of the following:

- a. Move the solar panel to an area with less obstructed sunlight.
  - b. Add a second solar panel, or add an AC charger.
  - c. Booster charge the battery at mid season.
4. Check water level in battery every three months. If the water level is low, fill it up with distilled water. Booster charge the battery with a 2A charge using a 10A charger in the beginning and end of the season.

### 5.3 REMOTE CONTROL INFORMATION

The remote transmitter can de-program due to either a power loss (dead battery) or electrical interference, which will require re-programming of the transmitter.

Proper function of the RC system is dependent upon several factors that are not controllable by the manufacturer. RGC is not responsible for the following: Improper installation, low battery, natural occurrences, use other than intended, location of panel, receiver or transmitter too close to interfering metal objects, multiple RC panels within 15 feet of each other, use in area with external interference such as radio, cell phone, and TV towers or a natural magnetic field, Blocked or shielded antenna, Other transmitter interference from cell phones, cordless phones, wireless systems, CB and mobile transmitters, computer and industrial equipment, electric motors, even fluorescent lights.

#### Reprogramming Your GEM Remote Control

In the event that you may need to reprogram your remote control unit, please follow these step instructions:

#### Programming GEM Transmitters on NEWER UNITS (Yellow transmitters with 3 blue buttons.)

1. Press the **LEARN** button once and release located on the **GEM control box mounted inside the fiberglass dock box.**
2. Press the **STOP** button within 5 seconds of pressing the **LEARN** button to program the transmitter.

### 5.4 ANNUAL INSPECTION

At least once a year, the lift must be thoroughly inspected using the following procedure.



#### **WARNING:**

**DO NOT ALLOW ANYBODY TO USE THE LIFT UNTIL THIS MAINTENANCE IS COMPLETED.**

1. Tighten all bolts.
2. Clean cylinder rods.
3. Check that all the pivot pins are lubricated properly.
4. Check frame thoroughly for defects.
5. Inspect all hydraulic lines, fittings and hoses for leaks and risks of rupture as follows:
  - a. Inspect each hydraulic line, fitting, and hose for breaks, cracks, worn spots, bulges, chemical attack, kinks or any other damage. Never try to stop any detected leak with any body parts. Do not put your face close to suspected leaks. Hold a piece of cardboard close to suspected leaks and then inspect the cardboard for signs of hydraulic oil.



**WARNING:**

**LIQUID UNDER HIGH PRESSURE CAN PIERCE THE SKIN, CAUSING DEATH OR SERIOUS INJURY. IN CASE OF INJURY, GET IMMEDIATE MEDICAL ATTENTION.**

- b. Replace a damaged line, fitting or hose immediately. Never repair the part.

**5.5 STORAGE PROCEDURE**



**CAUTION:**

**DO NOT STORE THE POWER UNIT IN AN AREA WHERE FREEZING TEMPERATURES ARE EXPECTED. THIS WILL CAUSE EQUIPMENT DAMAGE.**

1. Wipe cylinder rods before storing hydraulic lift at the end of the season.
2. Disconnect and store battery fully charged to prevent from freezing.
3. Disconnect and store hydraulic cylinders, hydraulic hoses, and control box in a warm dry area if temperatures or wind chill factors below minus 20 degrees F are expected.

## 5.6 HYDRAULIC SYSTEM FLUSH

It is recommended that as part of an annual maintenance program, the hydraulic system be drained and fresh Vegetable Grade hydraulic oil installed. RGC recommends CITGO Aqua Marine Hydraulic 46, GULF GREEN NS AW 46 (or equivalent biodegradable oil) be used.

1. Lower the platform until the cylinders are fully retracted.



### **WARNING:**

**FOLLOW THE SAME SAFETY RULES WHEN WORKING INSIDE THE CONTROL BOX AND AROUND THE BATTERY THAT APPLY TO ANY CAR OR BOAT BATTERY. A BATTERY CAN EXPLODE AND CAUSE PERSONAL INJURY AND/OR EQUIPMENT DAMAGE.**

2. Disconnect couplings between cylinder hoses and control box.
3. Unscrew reservoir oil fill cap.
4. Siphon old oil from reservoir using a hand siphon or vacuum pump. If not available, remove the 12-volt battery from control box, and very carefully tip over the control box to drain oil from reservoir into a bucket.
5. Remove reservoir from pump assembly to inspect oil filter screen. Be careful not to damage O-ring seal for reservoir. If necessary, clean the filter screen with soap and water.
6. Reassemble reservoir and pump assembly, then fill reservoir with fresh CITGO Aqua Marine Hydraulic 46.



### **WARNING:**

**LIQUID UNDER HIGH PRESSURE CAN PIERCE THE SKIN, CAUSING DEATH OR SERIOUS INJURY. IN CASE OF INJURY, GET IMMEDIATE MEDICAL ATTENTION.**

7. Depressurize cylinder hoses as follows:
  - a. Depressurize the cylinder hose with male coupling by wrapping a rag around the coupling (to prevent spray) and carefully pressing the end button against a hard flat surface. Use caution to avoid damaging the coupling button.
  - b. Depressurize the cylinder hose with female coupling by wrapping a rag around coupling (to prevent spray) and carefully press the internal button using a 3/8" bolt. Be very careful not to damage the internal O-rings. Be sure that both couplings are kept clean at all times.
9. Clean the lower cylinder hose coupling and reconnect to the control box.
10. Connect a spare coupling or remove quick-disconnect from the upper cylinder hose assembly.
11. While holding open hose end over a suitable container, press the UP button until cylinders are fully extended.
12. Reverse the hoses so that the spare fittings are on lower cylinder hose.
13. Be sure to keep reservoir filled with new oil.
14. While holding open hose end over a suitable container, press the DOWN button until cylinders are fully retracted.
15. Repeat steps 10 to 13 until oil coming from disconnected hose is clean. Then reconnect hose couplings to control box.
16. As these procedures are performed, additional oil may need to be added to the reservoir. Perform a final check of oil level with cylinders fully retracted.

## 6 TROUBLESHOOTING

The following chart is intended to assist with troubleshooting your hydraulic lift. While not all inclusive, the chart outlines the most common causes of a problem and the recommended course of action.



**CAUTION:**

**IF THE PROBLEM WITH THE POWER SUPPLY IS NOT CERTAIN, ALWAYS FOLLOW THE MANUFACTURER’S WARRANTY POLICY BEFORE ANY OTHER REPAIR OR MAINTENANCE IS ATTEMPTED.**



**WARNING:**

**NEVER ALLOW ANYBODY TO WORK IN OR ON THE BOAT WHEN IT IS SUSPENDED ABOVE THE WATER ON THE LIFT.**



**WARNING:**

**DO NOT SERVICE THE HYDRAULIC LIFT WITH YOUR BOAT ON THE LIFT. DO NOT SERVICE THE HYDRAULIC LIFT WITH LOAD TUBES IN THE RAISED POSITION. DO NOT DISCONNECT ANY HYDRAULIC LINES UNLESS THE LIFT IS COMPLETELY LOWERED.**

SYMPTOM	CAUSE AND CORRECTIVE ACTION
Power Unit does not function.	Check for blown 20A fuse (located inside GEM RC box). Check for broken wires or poor connections on switches and motor. See schematic figure 6-1.
Hoses cannot be connected.	System is pressurized. Depressurize the hoses as follows: <ul style="list-style-type: none"> <li>a. Depressurize the male fitting by carefully pressing the button on the end of the nipple or by briefly tapping the down switch. Use caution to avoid damaging the nipple button.</li> <li>b. Depressurize the female fitting by tapping the “up” switch briefly, which will depressurize the pump. If necessary, depressurize the female fitting on the hose by carefully pressing the internal button using a 3/8” bolt. Be careful not to damage the internal O-rings. Wrap the fitting with a rag while depressurizing to prevent spray. Keep the connectors clean.</li> </ul>
Battery does not keep a charge.	Check the battery fluid levels, age, and time of last booster charge. The battery must be booster charged at the beginning and end of the season using a 10A charger.  Verify solar panel or AC charger is plugged in correctly.  Check the voltage output of the solar panel. With solar panel unplugged, output should be about 14-18 volts when exposed to light.  Verify that the polarity (positive or negative) of the solar panel matches the battery’s polarity.
Battery terminal becomes hot.	Verify cable is clean and tight on battery terminal
Solar Panel- no output.	Verify that the solar panel gets an adequate amount of light and the lift usage is within the monthly seasonal limits. The solar panel may be mounted up to 50 feet away from the battery if necessary.  Verify the solar panel has a voltage output. Unplug solar panel and check voltage at plug with voltmeter. The voltage should be between 17-21V in direct sunlight. If not, the solar panel, cable or diode could be damaged.

SYMPTOM	CAUSE AND CORRECTIVE ACTION
Remote control range is limited.	Check battery in key chain transmitter. If the range is only limited while in your boat, try holding the transmitter over your head. Proximity to cell phone towers, power lines, and other electromagnetic interference can also reduce remote control range.
Remote control not functioning.	The remote control is designed to stop working if the battery drops below 11 volts to alert the user that the battery is getting low. If the lift operates with the up/down switch in the power supply, but not with the remote, charge the battery using a 10A booster charger.
Fluid overflows reservoir.	It is normal to see some fluid overflow from the reservoir when the platform is cycled all the way down the first few times.
Lift stops after a split second.	Battery is low. If the battery is becoming low, the remote control will stop functioning at about 11 volts. The lift can still be operated using the up/down switch in the power supply, but the pump motor will stop and the green solenoid light will shut off if the voltage drops below 9 volts. Charge the battery using a 10A charger.
Power unit is operating properly, but platform raising is either difficult or impossible.	<p>Platform is binding because frame is either not square or not set level in the water- refer to Chapter 3 in the lift manual.</p> <p>Load exceeds rated capacity- reduce load weight as needed. User or dealer installed locking devices are in place—remove these.</p> <p>Auxiliary equipment such as boating hardware is being improperly hung on lift-remove this equipment permanently.</p> <p>Hoses to cylinders are leaking fluid in line, have a poor connection, or are kinked.</p> <p>Hydraulic system malfunctioning-contact your authorized service center.</p>
Cylinders fail to hold the platform in a given position as described in the test procedure of Section 4.2	<p>Check hose connections. Could have a bad ‘DOWN’ valve cartridge not holding the lift position.</p> <p>Contact your authorized dealer- tampering with the hydraulic system can cause equipment damage that may invalidate your warranty.</p>
Lift does not go down.	<p>Check GREEN wire wiring on switches and solenoid. Verify 12V+ is at the ‘DOWN’ solenoid. Disconnect wire from ‘Down’ solenoid, use a voltmeter to check voltage output to solenoid when energizing in the down direction.</p> <p>Check hose couplers are screwed together tight.</p>
Lift does not go up.	<p>Check YELLOW wire wiring on switches and solenoid. Verify 12V+ is at the ‘UP’ solenoid. Disconnect wire from ‘UP’ solenoid, use a voltmeter to check voltage output to solenoid when energizing in the up direction.</p> <p>Check hose couplers are screwed together tight.</p>
Pump motor will not run.	<p>Check WHITE wire wiring on motor start solenoid. Verify 12V+ is at motor start solenoid. Use a voltmeter to check voltage output to white wire on solenoid when energizing in both UP &amp; DOWN direction. If voltage is present when operating the lift, the motor or motor solenoid is bad. If voltage is not present, the diodes in the circuit are bad.</p>



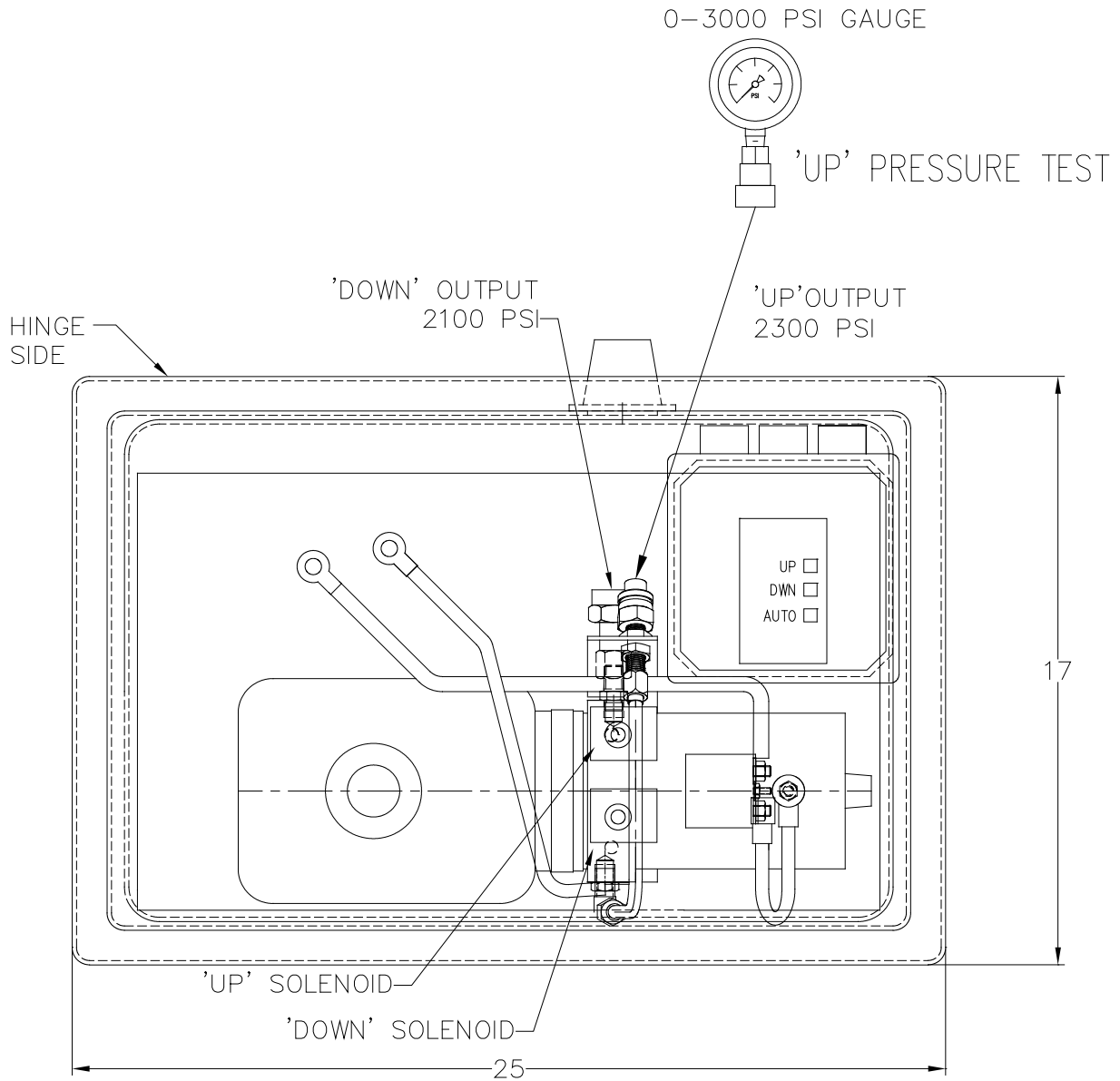

Figure 6-1  
HL & HVL Power Unit Pressure Test

LIFT	PRESSURE SETTINGS
HL40120, HL50120, HL50120XL, HL 70120, HL7012XL, HL90120, HL90120XL	'UP' pressure setting- 2300 PSI. 'DOWN' pressure setting- 2000PSI.
HVL40108, HVL 40116, HVL50124, HVL50124T	'UP' pressure setting- 2600 PSI. 'DOWN' pressure setting- 2000PSI.
HVL70124T	'UP' pressure setting- 2800 PSI. 'DOWN' pressure setting- 2000PSI.

NOTE: Do not exceed recommended pressure settings. Contact your authorized dealer- tampering with the hydraulic system can cause equipment damage that may invalidate your warranty.

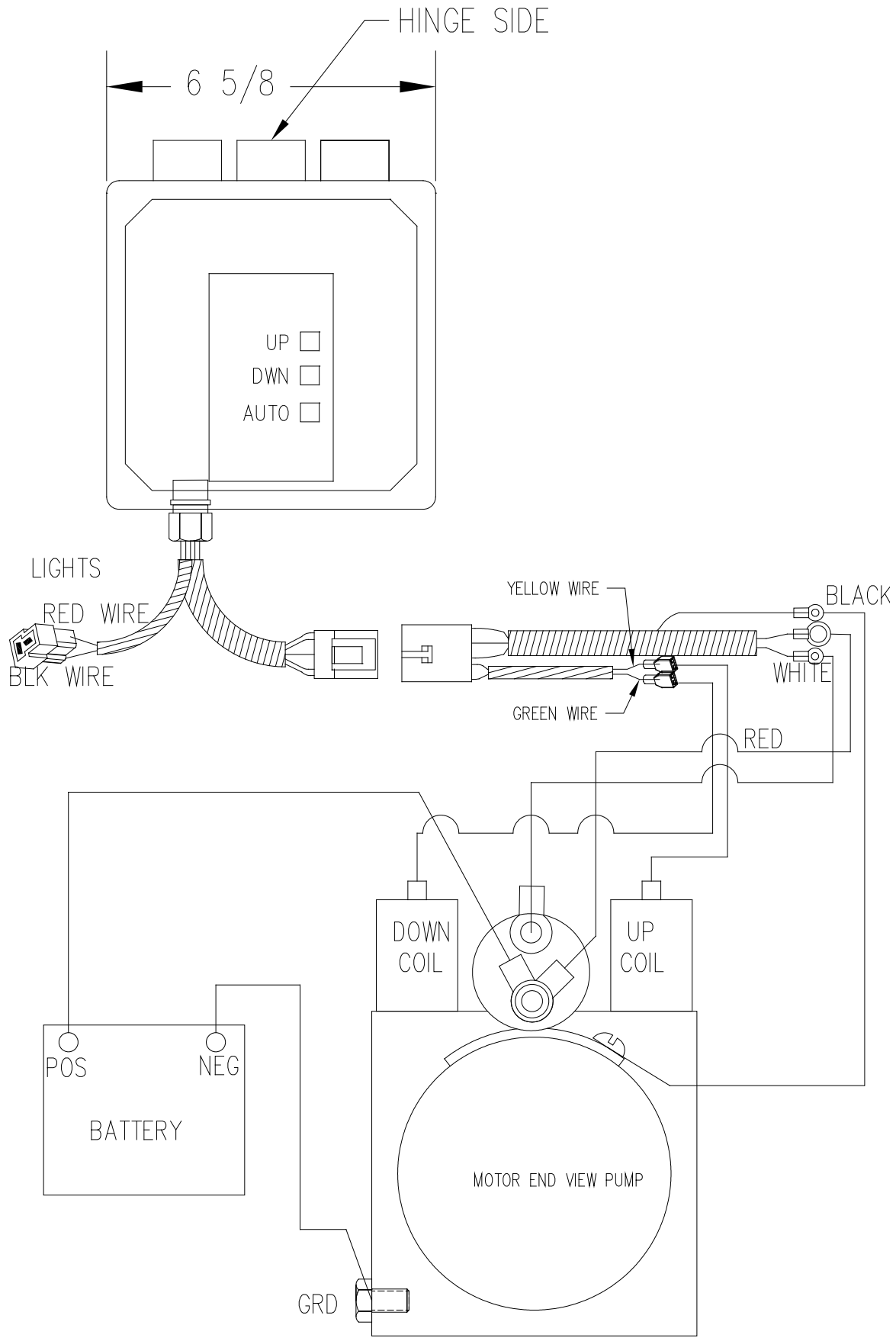

Figure 6-2  
HL & HVL Power Unit Electrical Schematic

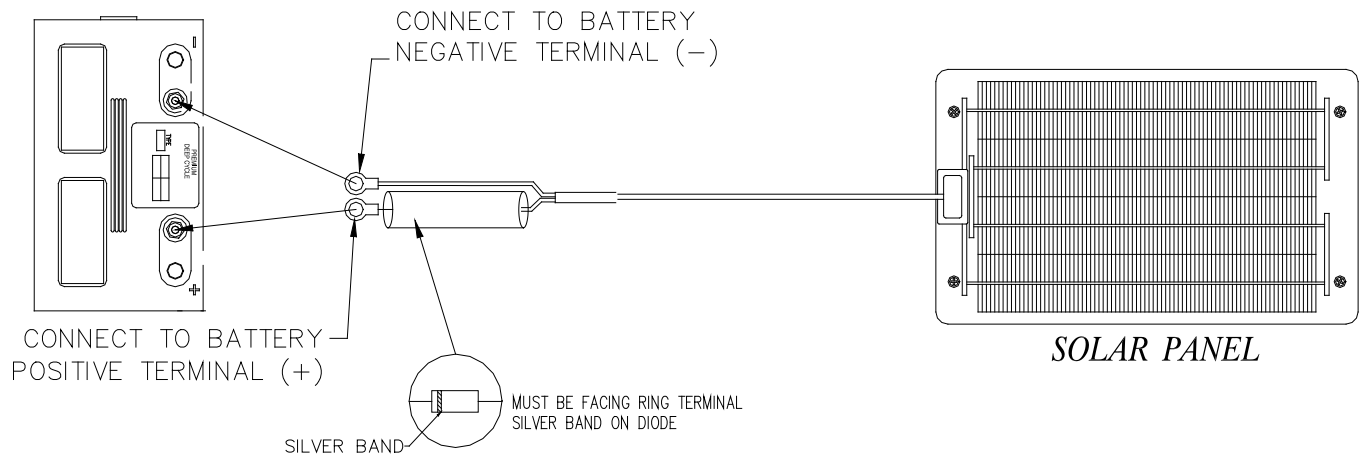

Fig 6-4  
12V SOLAR PANEL W/RING TERMINALS (OPTIONAL)

## 7 PARTS LISTS

Each reference number or letter in the following parts lists can be matched with the reference number or letter referred to in both the text and illustrations of Section 7.

### 7.1 4136104 HL4-9K CONTROL BOX 12VDC (STD) GEM RC and 3641611 HVL 4-7K CONTROL BOX 12VDC (STD) GEM RC

**Reference figure 7-1**

REF #	PART #	QTY	DESCRIPTION
1	6441363	1	FIBERGLASS DOCK BOX 3"
2	7841078	1	WAFER BOARD
3	6941314	1	HL HYDRAULIC PUMP
4	5806313	2	SCREW FH SOC 3/8-16 X 1
5	5641074	1	ADAPTER 90 DEGREE 9/16 SAE M X 9/16 JIC MALE
6	5641069	1	NUT HEX 9/16-18 BULK HEAD
7	5641070	1	ADAPTER 9/16JICM X 1/4NPTM BULKHEAD
8	6451003	1	CABLE BOOT 3" BLACK VINYL
9	5641072	1	ADAPTER 1/4NPT M X 9/16 SAE MALE
10	6041364	1	COUPLING 1/4 NPT FEMALE (SCREW TO CONNECT)
12	5896242	6	PAN HEAD PHIL SCREW 10-24 X 5/8 SS
13	5893100	10	NUT HEX NYLOCK THIN 10-24 SS
14	5894136	4	PAN HEAD PHIL SCREW 10-24 3/4 SS
15	5894102	10	WASHER FLAT SAE #10 SS
16	6041901	1	HL/HVL CONTROL BOX TUBE HYDRAULIC
17	3654107	1	HL/HVL RC ASSY 12VDC GEM '14
18	4136213	1	HL/HVL CONTROL BOX DC TUBE SUPT BRKT-ZCP
19	4107417	1	HL/HVL GEM BOX MOUNTING ASSEMBLY
20	5441115	1	HL BATTERY GROUND CABLE -BLACK
21	6205666	1	DECAL HL "BEFORE OPERATING"
23	5441065	1	TERMINAL, MALE QUICK-CONNECT 16-14 BLUE
	5441067	1	TERMINAL, MALE QUICK-CONNECT 22-18 RED
24	5441120	1	HL POSITIVE BATTERY CABLE -RED
25	6206977	1	DECAL "RGC MARINE LOGO" 3"
26	6041365	1	COUPLING 1/4 NPT MALE (SCREW TO CONNECT)
28	5441070	1	FUSE 20A (INSIDE GEM CONTROL BOX)
30	6206211	1	TAG MODEL MARINE "BOAT LIFT"
31	6316475	1 GAL	OIL MARINE BIODEGRADABLE
	5441373	1	12VDC FEMALE GEM WIRE HARNESS

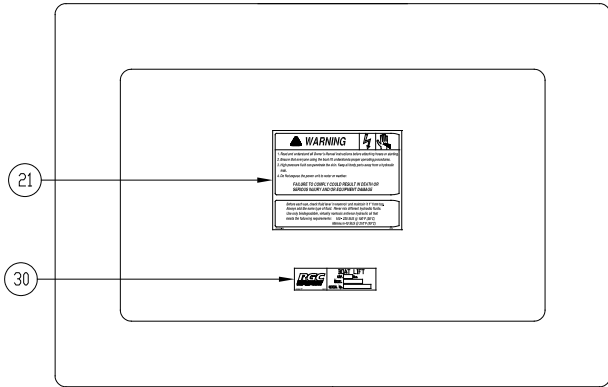

HINGE  
SIDE  
INSIDE LID  
VIEW

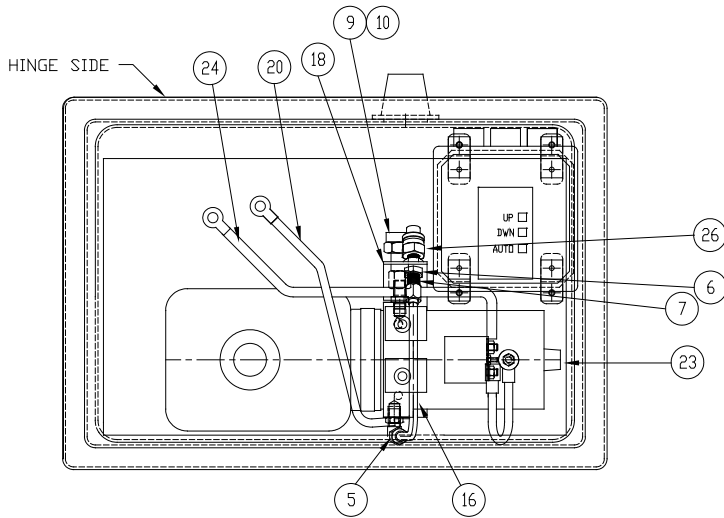

LID NOT SHOWN FOR CLARIFICATION

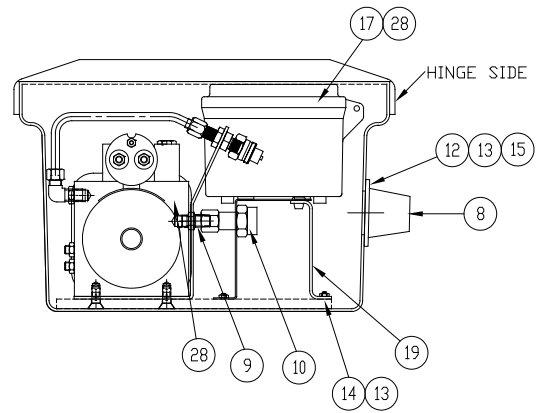
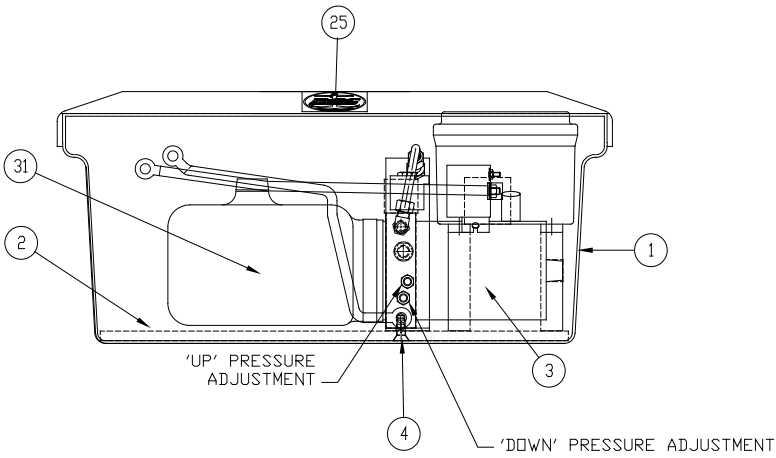

**Figure 7-1**  
**Complete HL & HVL Power Unit Assembly**

## LIMITED PRODUCT WARRANTY

### Reimann & Georger Corporation Marine Products

RGC Marine products, hereafter referred to as the “Manufacturer”, extend this limited warranty to the original purchaser of this product. The original purchaser, hereinafter referred to as the “Buyer”, is defined as the first legal owner of this product other than an authorized distributor or dealer who has bought the product from the Manufacturer for resale to the public. **The Buyer must complete and return the Warranty Registration section of the provided Warranty Card to make this limited warranty effective.**

### CONSUMER PRODUCT PROVISIONS

**I. ARTICLE I—CONSUMER PRODUCT PROVISIONS: THE FOLLOWING PROVISIONS SHALL BE APPLICABLE IF THIS PRODUCT IS BEING PURCHASED FOR PERSONAL, FAMILY OR HOUSEHOLD PURPOSES.**

**THE CONSUMER PRODUCT PROVISIONS CONTAINED IN THIS ARTICLE I SHALL APPLY UNLESS THIS PRODUCT IS BEING PURCHASED SOLELY FOR COMMERCIAL OR INDUSTRIAL USE, IN WHICH EVENT THE PROVISIONS CONTAINED IN ARTICLE II BELOW SHALL APPLY AND THE PROVISIONS CONTAINED IN THIS ARTICLE I SHALL BE INAPPLICABLE.**

#### **A. 1-YEAR LIMITED WARRANTY**

The Manufacturer warrants to the Buyer that all supplied parts shall be free of defects in material and workmanship for a period of one (1) year from date of original purchase. This limited warranty covers the cost of all parts and labor needed to repair any item that is found to be defective in material and workmanship. Items covered include hydraulic unit, cylinders, hoses, bearings and remote control.

#### **B. 15-YEAR LIMITED WARRANTY ON HL SERIES ALUMINUM FRAME EXTRUSION**

The Manufacturer warrants to the Buyer that the frame and extrusions shall be free of defects in material and workmanship for a period of fifteen (15) years from date of original purchase. This limited warranty covers the cost of all parts and labor needed to repair any item that is found to be defective in material and workmanship.

#### **C. MANUFACTURER’S OBLIGATIONS**

The Manufacturer’s sole obligation under either of these limited warranties is the replacement or repair, at the Manufacturer’s discretion, of parts found to be defective.

#### **D. NO SPECIAL, INCIDENTAL OR CONSEQUENTIAL DAMAGES**

**IN NO EVENT SHALL THE MANUFACTURER BE LIABLE TO THE BUYER OR ANY PERSON FOR ANY INDIRECT, SPECIAL, INCIDENTAL, OR CONSEQUENTIAL LOSSES OR DAMAGES CONNECTED WITH THE USE OF THE PRODUCT UNDER WARRANTY. SUCH DAMAGES FOR WHICH THE MANUFACTURER SHALL NOT BE RESPONSIBLE INCLUDE, BUT ARE NOT LIMITED TO, LOST TIME AND CONVENIENCE, LOSS OF USE OF THE PRODUCT, THE COST OF A PRODUCT RENTAL, COSTS OF GASOLINE, TELEPHONE, TRAVEL, OR LODGING, THE LOSS OF PERSONAL OR COMMERCIAL PROPERTY, AND THE LOSS OF REVENUE.**

Some States do not allow the exclusion or limitation of incidental or consequential damages, so the above limitation or exclusion may not apply to you.

#### **E. NO LIABILITY IN EXCESS OF PURCHASE PRICE**

**IN NO EVENT SHALL THE MANUFACTURER’S OBLIGATIONS UNDER THIS LIMITED WARRANTY EXCEED THE PURCHASE PRICE OF THE PRODUCT.**

**F. NO EXTENSION OF STATUTE OF LIMITATIONS**

**ANY REPAIRS PERFORMED UNDER EITHER OF THESE WARRANTIES SHALL NOT IN ANY WAY EXTEND THE ONE-YEAR AND FIFTEEN-YEAR STATUTES OF LIMITATIONS CONTAINED IN THIS LIMITED WARRANTY.**

**G. PROCEDURE FOR WARRANTY PERFORMANCE**

If the product fails to perform to the Manufacturer's specifications, the Buyer must contact the dealer from whom the product was purchased. The Buyer must provide the dealer with the applicable model and serial numbers, the date of purchase, and the nature of the problem.

**H. PREAPPROVAL OF LABOR COSTS**

All labor costs related to a dealer's performance of the warranty obligations under this limited warranty must be pre-approved by Reimann & Georger Corp. Marine Products.

**I. NO OTHER EXPRESS WARRANTIES**

**THE MANUFACTURER IS NOT SUBJECT TO ANY EXPRESS WARRANTIES OTHER THAN THOSE SET FORTH ABOVE.**

**J. LIMIT ON DURATION OF IMPLIED WARRANTIES**

**THE DURATION OF ANY IMPLIED WARRANTIES UNDER APPLICABLE STATE LAW RELATING TO THE PURCHASE OF THIS PRODUCT SHALL BE LIMITED TO A PERIOD OF ONE (1) YEAR FROM THE DATE OF PURCHASE.**

Some States do not allow limitations on how long an implied warranty lasts, so the above limitations may not apply to you.

**K. QUESTIONS REGARDING LIMITED WARRANTY**

Any questions regarding this limited warranty or the procedure which the consumer should follow in order to obtain performance of any warranty obligation may be addressed to either the dealer from whom this product is purchased or to Reimann & Georger Corp. Marine Products, 1849 Harlem Rd., Buffalo, NY 14212.

**L. EXCLUSIONS FROM LIMITED WARRANTY. THIS LIMITED WARRANTY DOES NOT COVER ANY OF THE FOLLOWING:**

1. Equipment which has been abused, damaged, used beyond rated capacity, or which is damaged or has defects caused by repairs or service completed by persons other than authorized service personnel.
2. Costs of repairing damage caused by environmental factors which include, but are not limited to, airborne fallout, chemicals, tree sap, salt, ocean spray, and water hazards.
3. Damage caused by acts of God which include, but are not limited to, hailstorms, windstorms, tornadoes, sandstorms, lightning, floods, and earthquakes.
4. Damage under conditions caused by fire or accident, by abuse or negligence, by improper installation, by misuse, by incorrect operation, by "normal wear and tear", by improper adjustment or alteration, by alterations not done by the Manufacturer, or by failure of product parts from such alterations.
5. Costs of repairing damage caused by poor or improper maintenance, costs of normally scheduled maintenance, or the cost of replacing any parts unless done as the result of a repair covered by your one-year limited warranty.
6. Costs of modifying the product in any way once delivered to the Buyer, even if such modifications were added as a production change on other products made after the Buyer's product was built.

**M. RIGHT TO MODIFY PRODUCT**

The Manufacturer has the right to modify this product at any time without incurring any obligation to make the same or similar modifications on products previously purchased.

**N. NO AUTHORITY TO ALTER WARRANTY**

No agent, representative, distributor or dealer has any authority to alter the terms of this warranty in any way.

**O. SPECIFIC LEGAL RIGHTS**

This warranty gives you specific legal rights and you may also have other rights, which vary, from State to State.



## **COMMERCIAL PRODUCT PROVISIONS**

**II. ARTICLE II—COMMERCIAL PRODUCT PROVISIONS: THE FOLLOWING PROVISIONS SHALL BE APPLICABLE ONLY IF THIS PRODUCT IS BEING PURCHASED SOLELY FOR COMMERCIAL OR INDUSTRIAL USE. IF THIS PRODUCT IS BEING PURCHASED FOR PERSONAL, FAMILY OR HOUSEHOLD PURPOSES, THE PROVISIONS CONTAINED IN THIS ARTICLE II SHALL NOT BE APPLICABLE AND THE PROVISIONS CONTAINED IN ARTICLE I ABOVE SHALL APPLY.**

### **A. 1-YEAR LIMITED WARRANTY**

The Manufacturer warrants to the Buyer that all supplied parts shall be free of defects in material and workmanship for a period of one (1) year from date of original purchase. This limited warranty covers the cost of all parts and labor needed to repair any item that is found to be defective in material and workmanship. Items covered include hydraulic unit, cylinders, hoses, bearings and remote control.

### **B. 5-YEAR LIMITED WARRANTY ON HL SERIES ALUMINUM FRAME EXTRUSION**

The Manufacturer warrants to the Buyer that the frame and extrusions shall be free of defects in material and workmanship for a period of five (5) years from date of original purchase. This limited warranty covers the cost of all parts and labor needed to repair any item that is found to be defective in material and workmanship.

### **C. MANUFACTURER'S OBLIGATIONS**

The Manufacturer's sole obligation under either of these limited warranties is the replacement or repair, at the Manufacturer's discretion, of parts found to be defective.

### **D. NO SPECIAL, INCIDENTAL, OR CONSEQUENTIAL DAMAGES**

**IN NO EVENT SHALL THE MANUFACTURER BE LIABLE TO THE BUYER OR ANY PERSON FOR ANY INDIRECT, SPECIAL, INCIDENTAL, OR CONSEQUENTIAL LOSSES OR DAMAGES CONNECTED WITH THE USE OF THE PRODUCT UNDER WARRANTY. SUCH DAMAGES FOR WHICH THE MANUFACTURER SHALL NOT BE RESPONSIBLE INCLUDE, BUT ARE NOT LIMITED TO, LOST TIME AND CONVENIENCE, LOSS OF USE OF THE PRODUCT, THE COST OF A PRODUCT RENTAL, COSTS OF GASOLINE, TELEPHONE, TRAVEL, OR LODGING, THE LOSS OF PERSONAL OR COMMERCIAL PROPERTY, AND THE LOSS OF REVENUE.**

### **E. NO LIABILITY IN EXCESS OF PURCHASE PRICE**

**IN NO EVENT SHALL THE MANUFACTURER'S OBLIGATIONS UNDER THIS LIMITED WARRANTY EXCEED THE PURCHASE PRICE OF THE PRODUCT.**

### **F. NO EXTENSION OF STATUTE OF LIMITATIONS**

**ANY REPAIRS PERFORMED UNDER EITHER OF THESE WARRANTIES SHALL NOT IN ANY WAY EXTEND THE RESPECTIVE STATUTES OF LIMITATIONS CONTAINED IN THIS LIMITED WARRANTY.**

### **G. WAIVER OF OTHER WARRANTIES**

**THESE EXPRESS WARRANTIES ARE IN LIEU OF AND EXCLUDE ANY AND ALL OTHER WARRANTIES, EXPRESS OR IMPLIED, INCLUDING, BUT NOT LIMITED TO, THE IMPLIED WARRANTIES OR MERCHANTABILITY AND FITNESS FOR A PARTICULAR PURPOSE.**

### **H. PROCEDURE FOR WARRANTY PERFORMANCE**

If the product fails to perform to the Manufacturer's specifications, the Buyer must contact the dealer from whom the product was purchased. The Buyer must provide the dealer with the applicable model and serial numbers, the date of purchase, and the nature of the problem.

**I. PREAPPROVAL OF LABOR COSTS**

All labor costs related to a dealer's performance of the warranty obligations under this limited warranty must be pre-approved by Reimann & Georger Corp. Marine Products.

**J. EXCLUSIONS FROM WARRANTY. THIS LIMITED WARRANTY DOES NOT COVER ANY OF THE FOLLOWING:**

1. Equipment which has been abused, damaged, used beyond rated capacity, or which is damaged or has defects caused by repairs or service completed by persons other than authorized service personnel.
2. Costs of repairing damage caused by environmental factors which include, but are not limited to, airborne fallout, chemicals, tree sap, salt, ocean spray, and water hazards.
3. Damage caused by acts of God which include, but are not limited to, hailstorms, windstorms, tornadoes, sandstorms, lightning, floods, and earthquakes.
4. Damage under conditions caused by fire or accident, by abuse or negligence, by improper installation, by misuse, by incorrect operation, by "normal wear and tear", by improper adjustment or alteration, by alterations not done by the Manufacturer, or by failure of product parts from such alterations.
5. Costs of repairing damage caused by poor or improper maintenance, costs of normally scheduled maintenance, or the cost of replacing any parts unless done as the result of a repair covered by your one-year limited warranty.
6. Costs of modifying the product in any way once delivered to the Buyer, even if such modifications were added as a production change on other products made after the Buyer's product was built.

**K. RIGHT TO MODIFY PRODUCT**

The Manufacturer has the right to modify this product at any time without incurring any obligation to make the same or similar modifications on products previously purchased.

**L. NO AUTHORITY TO ALTER WARRANTY**

No agent, representative, distributor, or dealer has any authority to alter the terms of this warranty in any way.

**M. SPECIFIC LEGAL RIGHTS**

This warranty gives you specific legal rights, and you may also have other rights, which vary, from State to State.